



HANGING



CLIMBING



WALK/BALANCE



CATALOG COLLECTION	DYNAMICS
DIMENSIONS (L x W x H) in cm	455 x 370 x 330
MAXIMUM CFH	200
IMPACT ATTENUATING SURFACE	min. 44,75 m ² - MAX 48,75 m ²
SUGGESTED AGE OF USE	8+
COMPOSITION	<ul style="list-style-type: none"> - n°6 aluminium Ø120 round poles - n°2 recycled anti-slip HDPE decks - n°3 metal guardpanels - n°3 recycled HDPE sheet guardpanels - n°1 modular slide - n°1 recycled HDPE sheet climbing - n°1 metal ladder - n°1 monkey bars - n°1 metal arch climbing - n°1 spinner - n°2 recycled HDPE sheet decorations

SECURITY AREA

650

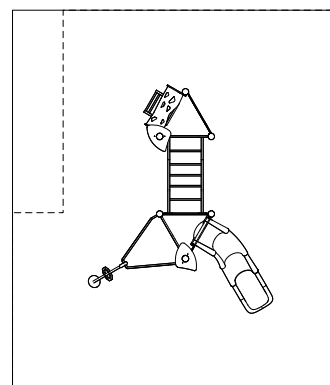

750

Make a proper security surface according to CFH. Periodic maintenance is mandatory, following manual supplied to customer.