

PRODUCT SHEET
REV 3.0 - EN202412
YX111 VIK



ORGANIZATION WITH QUALITY MANAGEMENT SYSTEM
ISO 9001:2015 CERTIFIED by
EuCI European Certification Institute LTD
Certificate N.: GOTT253201932

ORGANIZATION WITH ENVIRONMENTAL MANAGEMENT SYSTEM
ISO 14001:2015 CERTIFIED by
EuCI European Certification Institute LTD
Certificate N.: GOTT2532E1901



HANGING



CLIMBING



WALK/BALANCE



CATALOG COLLECTION	DYNAMICS
DIMENSIONS (L x W x H) in cm	240 x 255 x 330
MAXIMUM CFH	150
IMPACT ATTENUATING SURFACE	min. 30,25 m ² - MAX 30,25 m ²
SUGGESTED AGE OF USE	8+
COMPOSITION	<ul style="list-style-type: none"> - n°3 aluminium Ø120 round poles - n°1 recycled anti-slip HDPE deck - n°1 metal guardapanel - n°2 recycled HDPE sheet guardapanel - n°1 modular slide h150 - n°1 metal ladder - n°1 metal stepladder - n°1 recycled HDPE and metal sheet climbing - n°1 recycled HDPE sheet decoration

SECURITY AREA

← 550 →

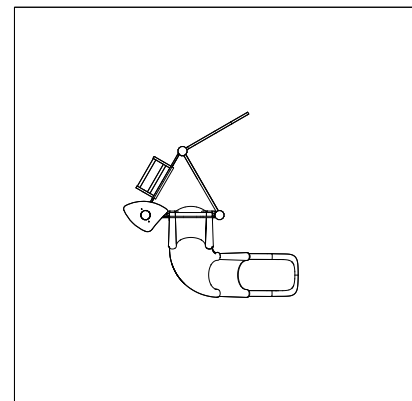

Make a proper security surface according to CFH. Periodic maintenance is mandatory, following manual supplied to customer.