

PRODUCT SHEET
REV 2.0 - EN202410
4310 LARA



ORGANIZATION WITH QUALITY MANAGEMENT SYSTEM
ISO 9001:2015 CERTIFIED by
EuCI European Certification Institute LTD
Certificate N.: GOTT253201932

ORGANIZATION WITH ENVIRONMENTAL MANAGEMENT SYSTEM
ISO 14001:2015 CERTIFIED by
EuCI European Certification Institute LTD
Certificate N.: GOTT2532E1801



SLIDING



CLIMBING



INTERACTIVE GAME

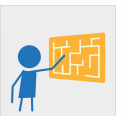

CATALOG COLLECTION	TIKA LINE
DIMENSIONS (L x W x H) in cm	225 x 270 x 270
MAXIMUM CFH	100
IMPACT ATTENUATING SURFACE	min. 25,25 m ² - MAX 27,50 m ²
SUGGESTED AGE OF USE	3 +
COMPOSITION	<ul style="list-style-type: none"> - n°4 70 x70 mm octagonal section aluminium structural poles - n°2 recycled anti-slip HDPE decks - n°1 open metal guard panel - n°1 stairs with recycled anti-slip HDPE treads - n°2 HDPE sheet climbings - n°1 «PUZZLE» play panel - n°1 roto-molded PTE modular slide H100 - n°1 recycled HDPE sheet bench - n°1 recycled HDPE sheet decoration

SECURITY AREA

500

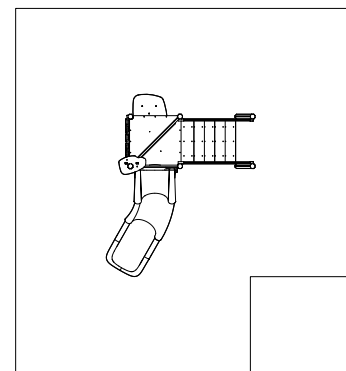

550

Make a proper security surface according to CFH. Periodic maintenance is mandatory, following manual supplied to customer.