



CLIMBING



SLIDING



<b>CATALOG COLLECTION</b>	TIKA LINE
<b>DIMENSIONS (L x W x H) in cm</b>	230 x 385 x 255
<b>MAXIMUM CFH</b>	100
<b>IMPACT ATTENUATING SURFACE</b>	min. 34,00 m <sup>2</sup> - MAX 38,50 m <sup>2</sup>
<b>SUGGESTED AGE OF USE</b>	3 +
<b>COMPOSITION</b>	<ul style="list-style-type: none"> <li>- n°6 70 x70 mm octagonal section aluminium structural poles</li> <li>- n°2 recycled anti-slip HDPE decks</li> <li>- n°2 open metal guard panel</li> <li>- n°1 recycled HDPE sheet decoration</li> <li>- n°1 metal ladder</li> <li>- n°1 metal perch</li> <li>- n°2 roto-molded PTE modular slides H100</li> <li>- n°2 recycled HDPE guard panels</li> </ul>

SECURITY AREA

550

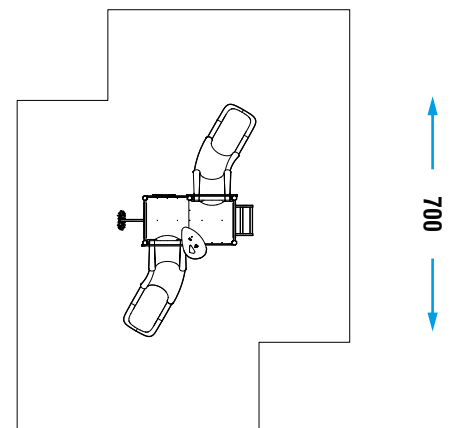

*Make a proper security surface according to CFH. Periodic maintenance is mandatory, following manual supplied to customer.*