

CATALOG COLLECTION	CODY LINE
DIMENSIONS (L x W x H) in cm	445 x 375 x 230
MAXIMUM CFH	60
IMPACT ATTENUATING SURFACE	min. 39,25 m ² - MAX 48,75 m ²
SUGGESTED AGE OF USE	1+
COMPOSITION	<ul style="list-style-type: none"> - n° 1 sandbox - n° 1 modular slide h60cm - n° 2 anti slip decks h60cm - n° 1 tunnel - n° 1 accessible stairs - support structure made in stainless steel 50x50x1.5 - n° 1 play panel Campane - n° 1 HDPE engraved play panel Labirinto - n° 1 play panel Blossom - n° 2 activity role play panels - n° 1 play panel Yon - n° 1 handling play panel - roof and posts' decorations made in HDPE - octagonal and square aluminum posts

SECURITY AREA

750

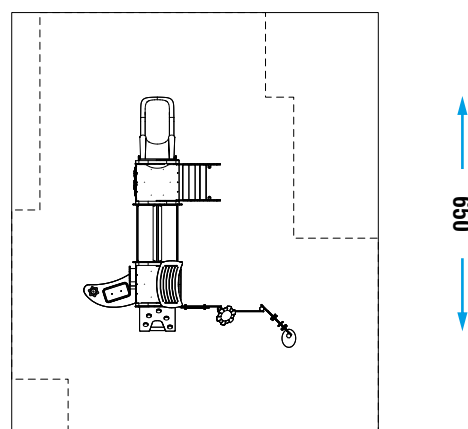

Make a proper security surface according to CFH. Periodic maintenance is mandatory, following manual supplied to customer.