

PRODUCT SHEET
REV 2.1 - EN202003
YX111 VIK



ORGANIZATION WITH QUALITY MANAGEMENT SYSTEM
ISO 9001:2015 CERTIFIED by
EuCI European Certification Institute LTD
Certificate N.: GOTT253201932

ORGANIZATION WITH ENVIRONMENTAL MANAGEMENT SYSTEM
ISO 14001:2015 CERTIFIED by
EuCI European Certification Institute LTD
Certificate N.: GOTT253201904



HANGING



CLIMBING



WALK/BALANCE



CATALOG COLLECTION	DYNAMICS
DIMENSIONS (L x W x H) in cm	290 x 310 x 330
MAXIMUM CFH	150
IMPACT ATTENUATING SURFACE	min. 31,75 m ² - MAX 36,00 m ²
SUGGESTED AGE OF USE	8+
COMPOSITION	<ul style="list-style-type: none"> - n°3 aluminium Ø127 round poles - n°1 aluminium deck - n°1 metal guardapanel - n°2 HDPE sheet guardapanel - n°1 modular slide - n°1 metal ladder - n°1 metal stepladder - n°1 HDPE and metal sheet climbing - n°1 HDPE sheet decoration

SECURITY AREA

590

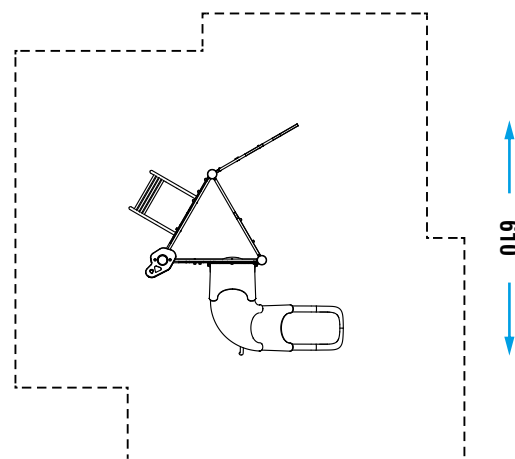

Make a proper security surface according to CFH. Periodic maintenance is mandatory, following manual supplied to customer.