

PRODUCT SHEET
REV 2.1 - EN202003
**901 TORRETTA
SCIVOLO DOPPIO**



ORGANIZATION WITH QUALITY MANAGEMENT SYSTEM
ISO 9001:2015 CERTIFIED by
EuCI European Certification Institute LTD
Certificate N.: GOTT253201932

ORGANIZATION WITH ENVIRONMENTAL MANAGEMENT SYSTEM
ISO 14001:2015 CERTIFIED by
EuCI European Certification Institute LTD
Certificate No: GOTT2532E1801



SLIDING



CATALOG COLLECTION	PLAYGROUND ESSENTIALS
DIMENSIONS (L x W x H) in cm	445 x 340 x 300
MAXIMUM CFH	125
IMPACT ATTENUATING SURFACE	min. 41,75 m ² - MAX 48,75 m ²
SUGGESTED AGE OF USE	3+
COMPOSITION	<ul style="list-style-type: none"> - n°4 aluminium poles - n°1 aluminium deck - n°2 HDPE sheet guardpanels - n°1 aluminium stairs - n°1 double slide

SECURITY AREA

625

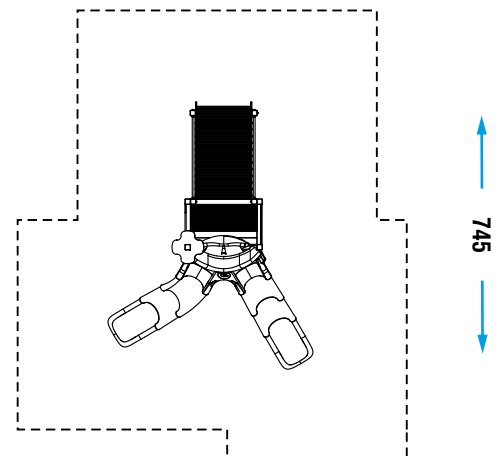

Make a proper security surface according to CFH. Periodic maintenance is mandatory, following manual supplied to customer.