



CLIMBING



INTERACTIVE
GAME



SLIDING



CATALOG COLLECTION	PARTY LINE
DIMENSIONS (L x W x H) in cm	405 x 330 x 320
MAXIMUM CFH	180
IMPACT ATTENUATING SURFACE	min. 35,00 m ² - MAX 39,00 m ²
SUGGESTED AGE OF USE	5 +

COMPOSITION

- n°6 octagonal profile aluminium structural poles
- n°2 powder coated aluminium treadplate decks
- n°3 metal guardpanels
- n°1 aluminium stair
- n°1 HDPE sheet entrance panel
- n°4 HDPE sheet climbings
- n°1 rotating mold PTE climber modules with sand quartz rosin handles
- n°2 HDPE sheet panels
- n°3 HDPE sheet playpanels
- n°1 rotating mold PTE modular slide
- n°1 HDPE sheet crossbar
- n°3 HDPE sheet decorations

SECURITY AREA

645

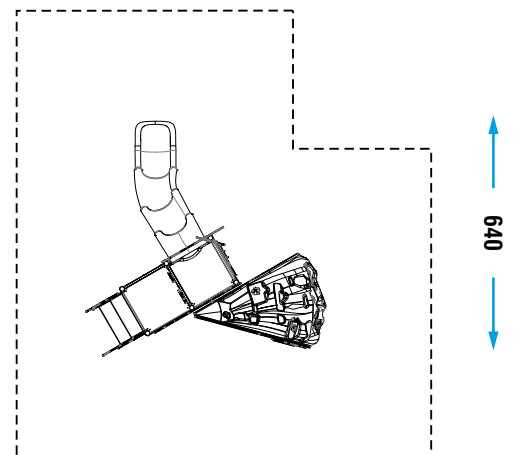

Make a proper security surface according to CFH. Periodic maintenance is mandatory, following manual supplied to customer.