

PRODUCT SHEET
REV 2.1 - EN202003
8005 LEONIDA



ORGANIZATION WITH QUALITY MANAGEMENT SYSTEM
ISO 9001:2015 CERTIFIED by
EuCI European Certification Institute LTD
Certificate N.: GOTT253201932

ORGANIZATION WITH ENVIRONMENTAL MANAGEMENT SYSTEM
ISO 14001:2015 CERTIFIED by
EuCI European Certification Institute LTD
Certificate No: GOTT2532E1801



INTERACTIVE
GAME



SWINGING



CLIMBING



SLIDING



CATALOG COLLECTION	PARTY LINE
DIMENSIONS (L x W x H) in cm	640 x 320 x 285
MAXIMUM CFH	90 (135)
IMPACT ATTENUATING SURFACE	min. (14,00) 46,50 m ² - MAX 60,00 m ²
SUGGESTED AGE OF USE	3 +
COMPOSITION	<ul style="list-style-type: none"> - n°6 timber or aluminium poles 9x9cm - n°2 timber or aluminium decks - n°3 metal guardpanels - n°1 HDPE sheet guardpanel - n°1 timber or aluminium closed stairs - n°2 modular slides - n°1 HDPE sheet playpanel - n°1 HDPE sheet bench - n°1 swing attachment

SECURITY AREA

750

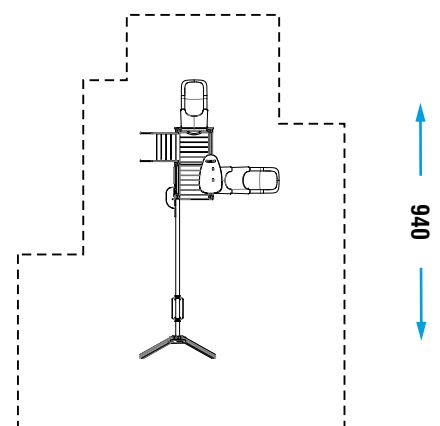

Make a proper security surface according to CFH. Periodic maintenance is mandatory, following manual supplied to customer.