

SCHEDA PRODOTTO
REV 1.0 - IT202104
8005C
LEONIDA COMPACT



ORGANIZATION WITH QUALITY MANAGEMENT SYSTEM
ISO 9001:2015 CERTIFIED by
EuCI European Certification Institute LTD
Certificate N.: GOTT253201932

ORGANIZATION WITH ENVIRONMENTAL MANAGEMENT SYSTEM
ISO 14001:2015 CERTIFIED by
EuCI European Certification Institute LTD
Certificate No: GOTT2532E1801



ARRAMPICARE



GIOCO INTERATTIVO

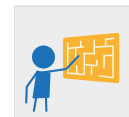

SCIVOLARE



COLLEZIONE	PARTY LINE
DIMENSIONI (L x P x H) in cm	320 x 285 x 285
ALTEZZA CRITICA DI CADUTA	90
AREA MIN/MAX ANTITRAUMA	min. 33,00 m ² - MAX 36,00 m ²
ETÀ D'USO CONSIGLIATA	3+
COMPOSIZIONE	<ul style="list-style-type: none"> - n°6 pali portanti in legno o in alluminio 9x9cm - n°2 pedane in legno o in alluminio - n°2 parapetti in metallo - n°2 parapetto in PTE rotazionale - n°1 scala chiusa in legno o in alluminio - n°2 scivoli modulari - n°2 pannelli gioco in lastra di HDPE - n°1 tettoia in lastra di HDPE

AREA DI SICUREZZA

← 575 →

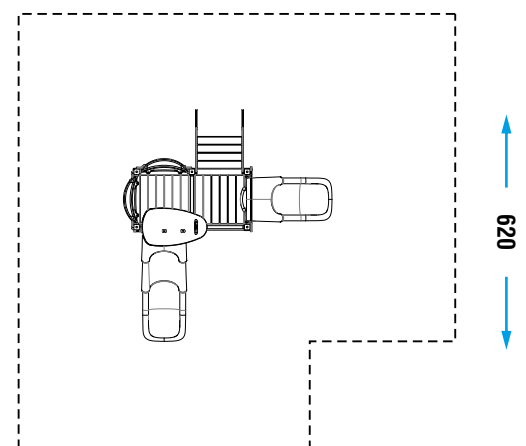

Realizzare un idoneo fondo antitrauma in funzione dell'altezza critica di caduta. Manutenzione periodica obbligatoria come da piano consegnato al cliente.