

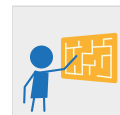

CLIMBING



INTERACTIVE
GAME



SLIDING



CATALOG COLLECTION	PARTY LINE
DIMENSIONS (L x W x H) in cm	320 x 285 x 285
MAXIMUM CFH	90
IMPACT ATTENUATING SURFACE	min. 33,00 m ² - MAX 36,00 m ²
SUGGESTED AGE OF USE	3+
COMPOSITION	<ul style="list-style-type: none"> - n°6 timber or aluminium poles 9x9cm - n°2 timber or aluminium decks - n°2 metal guardpanels - n°2 rotating mold PTE guardpanels - n°1 timber or aluminium closed stairs - n°2 modular slides - n°2 HDPE sheet playpanels - n°1 HDPE sheet canopy

SECURITY AREA

575

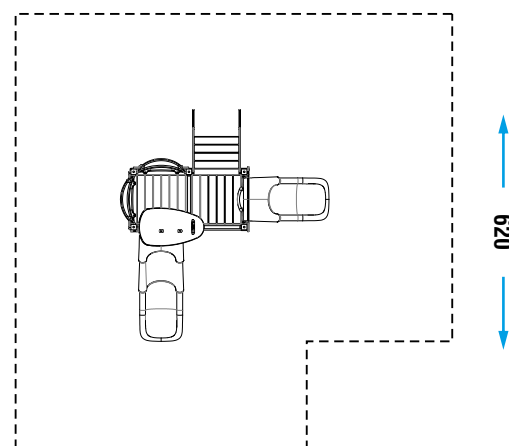

Make a proper security surface according to CFH. Periodic maintenance is mandatory, following manual supplied to customer.