



WALK/BALANCE



CRAWLING



CLIMBING



MEETING & ROLE PLAY



HANGING



SLIDING



CATALOG COLLECTION	PARTY LINE
DIMENSIONS (L x W x H) in cm	560 x 500 x 270
MAXIMUM CFH	100
IMPACT ATTENUATING SURFACE	min. 53,50 m ² - MAX 68,00 m ²
SUGGESTED AGE OF USE	3 +
COMPOSITION	<ul style="list-style-type: none"> - n°17 timber or aluminium poles 9x9cm - n°5 timber or aluminium decks - n°1 HDPE sheet roof - n°3 metal guardpanels - n°3 HDPE sheet guardpanels - n°1 modular slide - n°1 HDPE sheet climb - n°1 slope bridge - n°1 perch - n°1 tunnel - n°1 horizontal bar

SECURITY AREA

780

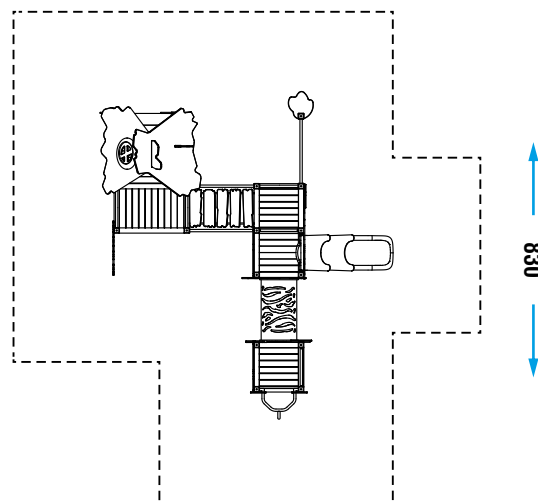

Make a proper security surface according to CFH. Periodic maintenance is mandatory, following manual supplied to customer.