



SWINGING



CLIMBING



SLIDING



CATALOG COLLECTION	FUN COLLECTION
DIMENSIONS (L x W x H) in cm	500 x 355 x 280
MAXIMUM CFH	118
IMPACT ATTENUATING SURFACE	min. 46,00 m ² - MAX (52,00) 64,00 m ²
SUGGESTED AGE OF USE	4 +
COMPOSITION	<ul style="list-style-type: none"> - n°4 timber or aluminium poles 9x9cm - n°1 timber or aluminium deck - n°1 HDPE sheet roof - n°2 HDPE sheet guardpanels - n°1 metal stepladder - n°1 modular slide - n°1 swing attachment

SECURITY AREA

780

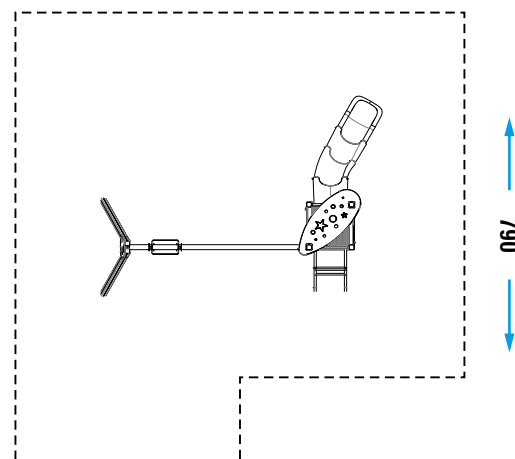

Make a proper security surface according to CFH. Periodic maintenance is mandatory, following manual supplied to customer.