

PRODUCT SHEET  
REV 2.1 - EN202003  
**6026 FOREST**



ORGANIZATION WITH QUALITY MANAGEMENT SYSTEM  
ISO 9001:2015 CERTIFIED by  
EuCI European Certification Institute LTD  
Certificate N.: GOTT253201932

ORGANIZATION WITH ENVIRONMENTAL MANAGEMENT SYSTEM  
ISO 14001:2015 CERTIFIED by  
EuCI European Certification Institute LTD  
Certificate N.: GOTT253201901



INTERACTIVE  
GAME



CLIMBING



SLIDING



<b>CATALOG COLLECTION</b>	FUN COLLECTION
<b>DIMENSIONS (L x W x H) in cm</b>	365 x 340 x 325
<b>MAXIMUM CFH</b>	125
<b>IMPACT ATTENUATING SURFACE</b>	min. 37,00 m <sup>2</sup> - MAX 42,25 m <sup>2</sup>
<b>SUGGESTED AGE OF USE</b>	3 +
<b>COMPOSITION</b>	<ul style="list-style-type: none"> <li>- n°6 timber or aluminium poles 9x9cm</li> <li>- n°2 timber or aluminium decks</li> <li>- n°1 gable roof</li> <li>- n°3 rotating mold PTE guardpanels</li> <li>- n°1 rotating mold PTE climbing</li> <li>- n°2 modular slides</li> <li>- n°1 metal playpanel</li> </ul>

SECURITY AREA

640

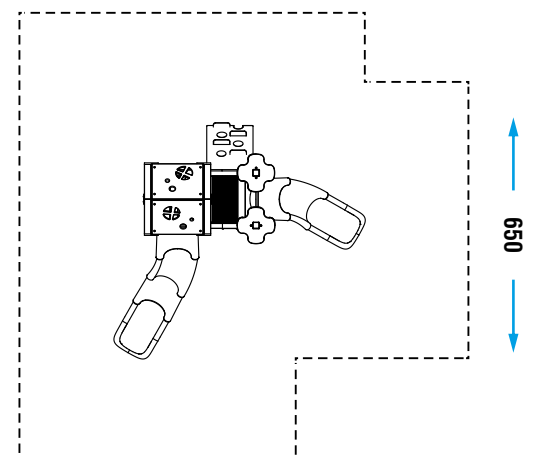

Make a proper security surface according to CFH. Periodic maintenance is mandatory, following manual supplied to customer.