

SCHEDA PRODOTTO  
REV 1.0 - IT202003  
**6008S**  
**SPAGNA SPECIAL**



ORGANIZATION WITH QUALITY MANAGEMENT SYSTEM  
ISO 9001:2015 CERTIFIED by  
EuCI European Certification Institute LTD  
Certificate N.: GOTT25201932

ORGANIZATION WITH ENVIRONMENTAL MANAGEMENT SYSTEM  
ISO 14001:2015 CERTIFIED by  
EuCI European Certification Institute LTD  
Certificate N.: GOTT2520E1804



ARRAMPICARE



SCIVOLARE



<b>COLLEZIONE</b>	FUN COLLECTION
<b>DIMENSIONI (L x P x H) in cm</b>	610 x 460 x 310
<b>ALTEZZA CRITICA DI CADUTA</b>	125
<b>AREA MIN/MAX ANTITRAUMA</b>	min. 61,00 m <sup>2</sup> - MAX 76,00 m <sup>2</sup>
<b>ETÀ D'USO CONSIGLIATA</b>	3 +
<b>COMPOSIZIONE</b>	<ul style="list-style-type: none"> <li>- n°8 pali portanti in legno o in alluminio 9x9cm</li> <li>- n°2 pedane in legno o in alluminio</li> <li>- n°1 tetto a due falde</li> <li>- n°1 parapetto in metallo</li> <li>- n°1 parapetto in PTE rotazionale</li> <li>- n°1 scala in legno o in alluminio</li> <li>- n°1 pertica in metallo</li> <li>- n°1 arrampicata ad arco in metallo</li> <li>- n°1 scivolo singolo</li> <li>- n°1 scivolo doppio con reggispinta in HDPE</li> <li>- n°1 decoro in lastra di HDPE</li> </ul>

AREA DI SICUREZZA

← 810 →

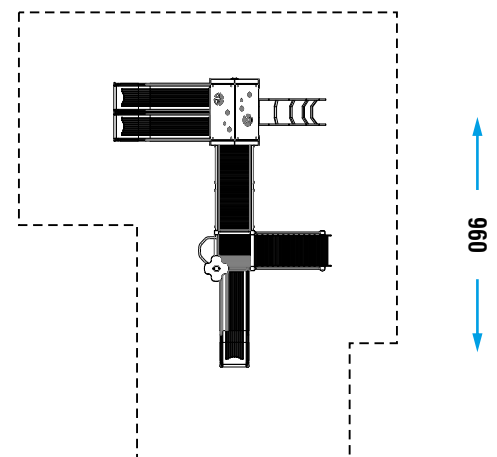

Realizzare un idoneo fondo antitrauma in funzione dell'altezza critica di caduta. Manutenzione periodica obbligatoria come da piano consegnato al cliente.