

PRODUCT SHEET
REV 2.1 - EN202003
555 CANAL GRANDE



ORGANIZATION WITH QUALITY MANAGEMENT SYSTEM
ISO 9001:2015 CERTIFIED by
EuCI European Certification Institute LTD
Certificate N.: GOTT25201902

ORGANIZATION WITH ENVIRONMENTAL MANAGEMENT SYSTEM
ISO 14001:2015 CERTIFIED by
EuCI European Certification Institute LTD
Certificate N.: GOTT25201901



INTERACTIVE
GAME



CLIMBING



SLIDING



CATALOG COLLECTION	CLASSIC COLLECTION
DIMENSIONS (L x W x H) in cm	520 x 580 x 320
MAXIMUM CFH	125
IMPACT ATTENUATING SURFACE	min. 54,50 m ² - MAX 68,00 m ²
SUGGESTED AGE OF USE	3 +
COMPOSITION	<ul style="list-style-type: none"> - n°10 timber or aluminium poles 9x9cm - n°3 timber or aluminium decks - n°1 pyramid roof - n°3 metal guardpanels - n°3 rotating mold PTE guardpanels - n°1 rotating mold PTE climbing - n°1 timber or aluminium stairs - n°1 slope bridge - n°1 modular slide with crossbar - n°1 HDPE sheet playpanel

SECURITY AREA

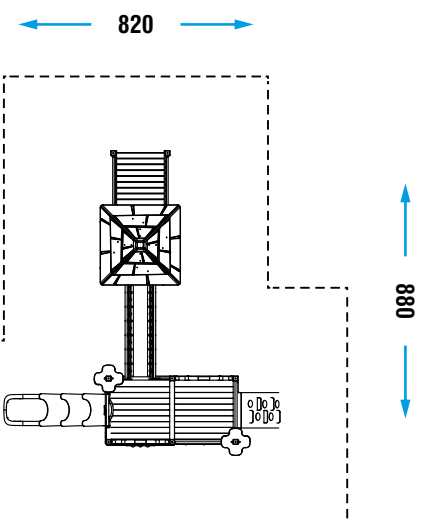

Make a proper security surface according to CFH. Periodic maintenance is mandatory, following manual supplied to customer.