

PRODUCT SHEET  
REV 1.0 - EN202003  
**4501 TIMOTHY**



ORGANIZATION WITH QUALITY MANAGEMENT SYSTEM  
ISO 9001:2015 CERTIFIED by  
EuCI European Certification Institute LTD  
Certificate N.: GOTT253201932

ORGANIZATION WITH ENVIRONMENTAL MANAGEMENT SYSTEM  
ISO 14001:2015 CERTIFIED by  
EuCI European Certification Institute LTD  
Certificate N.: GOTT2532E1901



SLIDING



CLIMBING



INTERACTIVE GAME



<b>CATALOG COLLECTION</b>	TIKA LINE
<b>DIMENSIONS (L x W x H) in cm</b>	515 x 435 x 290
<b>MAXIMUM CFH</b>	125
<b>IMPACT ATTENUATING SURFACE</b>	min. 51,25 m <sup>2</sup> - MAX 63,75 m <sup>2</sup>
<b>SUGGESTED AGE OF USE</b>	3 +
<b>COMPOSITION</b>	<ul style="list-style-type: none"> <li>- n°6 octagonal profile aluminium structural poles</li> <li>- n°2 powder coated aluminium treadplate decks</li> <li>- n°2 metal guardpanels</li> <li>- n°1 rotating mold PTE guardpanel</li> <li>- n°1 alluminium stair</li> <li>- n°2 HDPE sheet climbings</li> <li>- n°1 HDPE sheet playpanel</li> <li>- n°2 rotating mold PTE modular slides</li> <li>- n°1 rotating mold PTE double modular slide</li> <li>- n°2 HDPE sheet roof</li> </ul>

SECURITY AREA

735

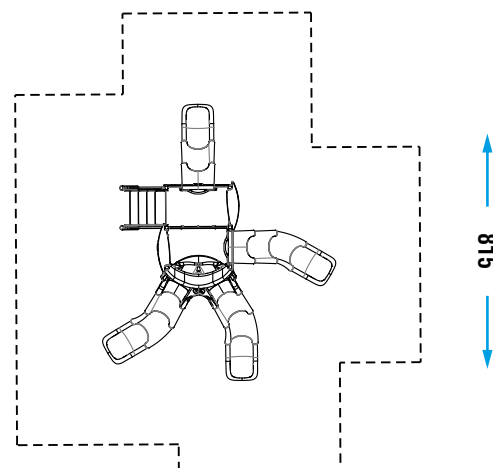

Make a proper security surface according to CFH. Periodic maintenance is mandatory, following manual supplied to customer.