

CATALOG COLLECTION	TIKA LINE
DIMENSIONS (L x W x H) in cm	225 x 270 x 270
MAXIMUM CFH	100
IMPACT ATTENUATING SURFACE	min. 25,25 m ² - MAX 27,50 m ²
SUGGESTED AGE OF USE	3 +

- COMPOSITION**
- n°4 octagonal profile aluminium structural poles
 - n°2 powder coated aluminium treadplate decks
 - n°1 metal guardpanel
 - n°1 aluminium stair
 - n°1 metal crossbar
 - n°2 HDPE sheet climbings
 - n°1 HDPE sheet playpanel
 - n°1 rotating mold PTE modular slide
 - n°1 HDPE sheet bench
 - n°1 HDPE sheet decoration

SECURITY AREA

530

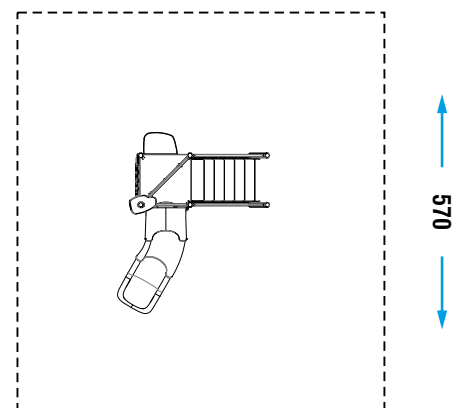

Make a proper security surface according to CFH. Periodic maintenance is mandatory, following manual supplied to customer.