

<b>CATALOG COLLECTION</b>	LET'S GET PHYSICAL
<b>DIMENSIONS (L x W x H) in cm</b>	250 x 370 x 250
<b>MAXIMUM CFH</b>	40
<b>IMPACT ATTENUATING SURFACE</b>	min. 38,50 m <sup>2</sup> - MAX 38,50 m <sup>2</sup>
<b>SUGGESTED AGE OF USE</b>	50+
<b>COMPOSITION</b>	<ul style="list-style-type: none"> <li>- n°7 timber or aluminium poles</li> <li>- n°1 panel for fingers exercise</li> <li>- n°1 panel for arms exercise</li> <li>- n°1 wrist exercise equipment</li> <li>- n°1 crossbar for legs exercise</li> <li>- n°2 equilibrium exercise tracks</li> </ul>

**SECURITY AREA**

550

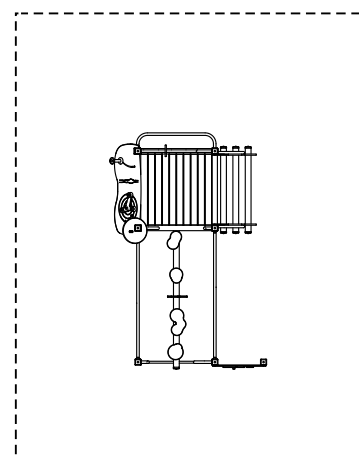

*Make a proper security surface according to CFH. Periodic maintenance is mandatory, following manual supplied to customer.*