

SECURITY AREA

380

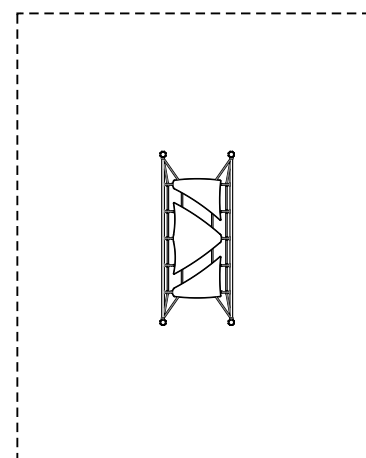

<b>CATALOG COLLECTION</b>	LET'S GET PHYSICAL
<b>DIMENSIONS (L x W x H) in cm</b>	190 x 80 x 90
<b>MAXIMUM CFH</b>	80
<b>IMPACT ATTENUATING SURFACE</b>	min. 20,00 m <sup>2</sup> - MAX 20,00 m <sup>2</sup>
<b>SUGGESTED AGE OF USE</b>	4+
<b>COMPOSITION</b>	- n°4 octagonal aluminium poles - n°1 rope net moving bridge with 19mm thick HDPE sheet panels

*Make a proper security surface according to CFH. Periodic maintenance is mandatory, following manual supplied to customer.*