



CLIMBING



SLIDING



CATALOG COLLECTION	PLAYGROUND ESSENTIALS
DIMENSIONS (L x W x H) in cm	370 x 315 x 250
MAXIMUM CFH	200
IMPACT ATTENUATING SURFACE	min. 37,50 m ² - MAX 42,00 m ²
SUGGESTED AGE OF USE	6+
COMPOSITION	<ul style="list-style-type: none"> - n°3 Ø127mm aluminium poles - n°1 aluminium deck - n°2 metal guardpanels - n°1 metal ladder - n°1 modular slide - n°1 rounded metal ladder - n°1 metal tubular and HDPE sheet climbing

SECURITY AREA

← 680 →

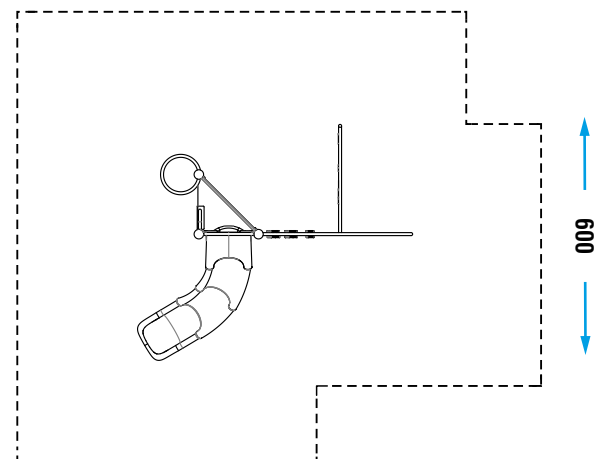

Make a proper security surface according to CFH. Periodic maintenance is mandatory, following manual supplied to customer.