

# PRODUCT SHEET

REV 1.0 - EN201909

## 0980 STEROPES



ORGANIZATION WITH QUALITY MANAGEMENT SYSTEM  
 ISO 9001:2015 CERTIFIED by  
 EuCI European Certification Institute LTD  
 Certificate N.: GOTT25201932

ORGANIZATION WITH ENVIRONMENTAL MANAGEMENT SYSTEM  
 ISO 14001:2015 CERTIFIED by  
 EuCI European Certification Institute LTD  
 Certificate N.: GOTT25201901

**CATALOG COLLECTION****NEWS****DIMENSIONS (L x W x H) in cm**

575 x 515 x 585

**MAXIMUM CFH:**

150

**IMPACT ATTENUATING SURFACE:**min. 5,25 m<sup>2</sup> - MAX 85,50 m<sup>2</sup>**SUGGESTED AGE OF USE**

4 +

**COMPOSITION**

- n°4 70x130 profile structural aluminium poles
- n°3 antislip aluminium decks with powder coated steel frame
- n°3 powder coated steel ladders
- n°14 powder coated steel barriers
- n°8 15 mm thick HDPE barriers
- n°3 tube slides
- n°1 15 mm thick HDPE roof

**SLIDING****CLIMBING****SECURITY AREA**

855

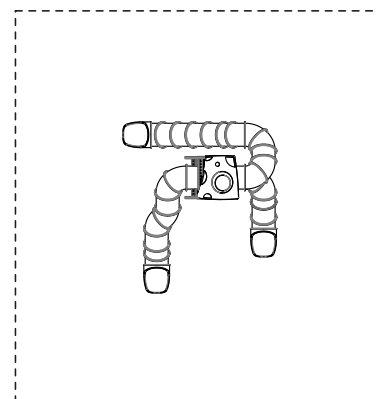

**NEW  
ALUMINIUM  
PROFILE**

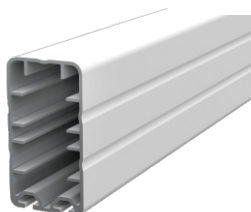

Make a proper security surface according to CFH. Periodic maintenance is mandatory, following manual supplied to customer.